

2021-2022学年秋季学期

第七部分 可编程逻辑电路

授课团队：宋威

助 教：薛子涵

可编程逻辑电路

可编程逻辑电路是一种半定制的大规模集成电路，允许电路在生产完成之后，通过配置，实现用户所需要的逻辑功能。

从简单到复杂，可编程逻辑电路分为：

- **PLA (programmable logic array)**
 - 由可编程逻辑阵列，与门和或门构成的可编程电路
 - 实现组合逻辑
- **PAL (programmable array logic)**
 - 在PLA的基础上添加D-FF，可用于实现时序逻辑
- **CPLD (complex programmable logic device)**
 - 大规模PAL阵列
- **FPGA (field programmable gate array)**
 - 使用更高密度的可编程逻辑阵列（传输门）和配置存储（SRAM）

- 由可编程逻辑阵列，与门和或门构成的可编程电路
- 实现组合逻辑

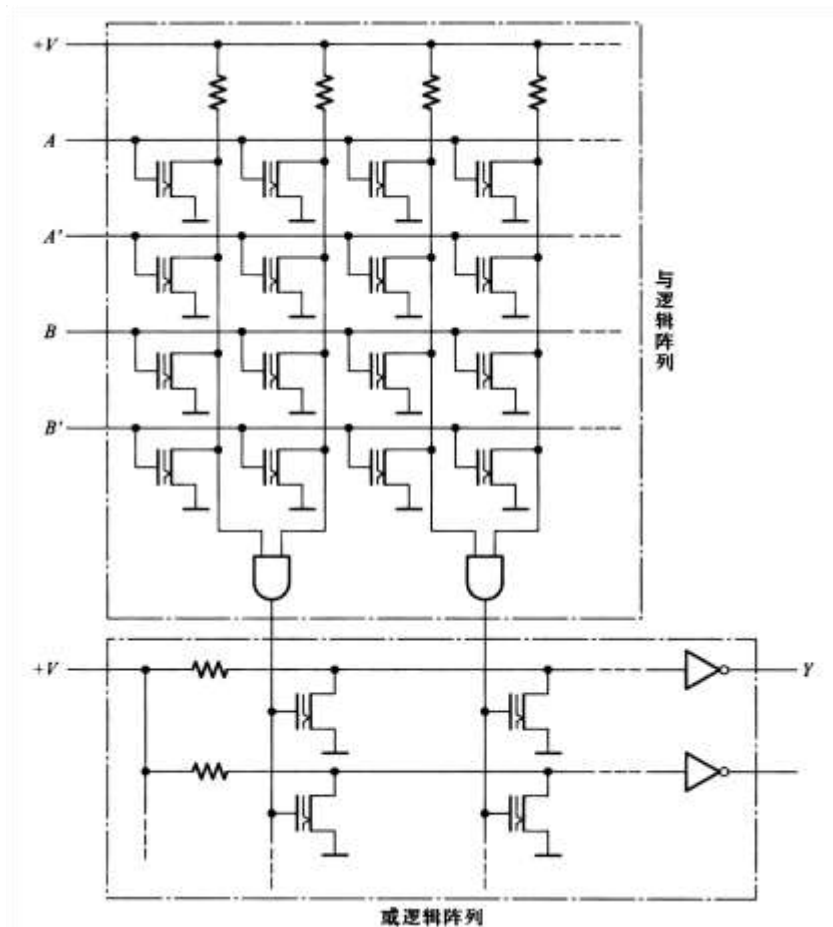
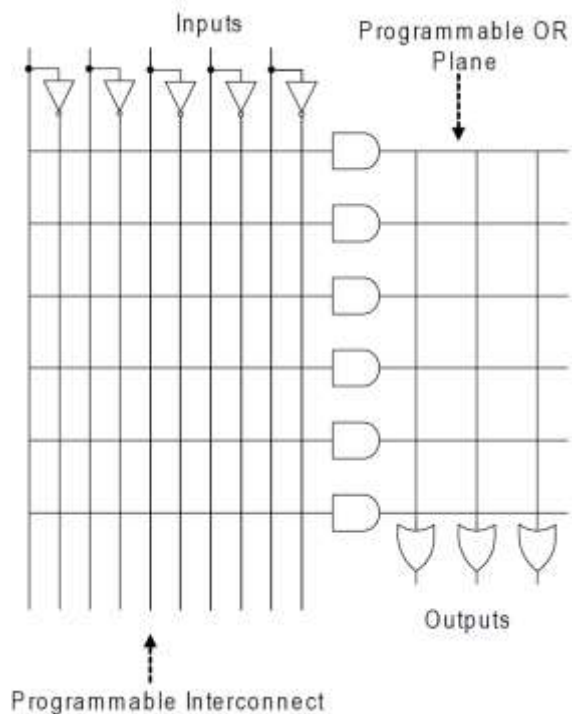

PAL

- 在PLA的基础上，添加带DFF的宏单元（macrocell）
- 实现时序逻辑

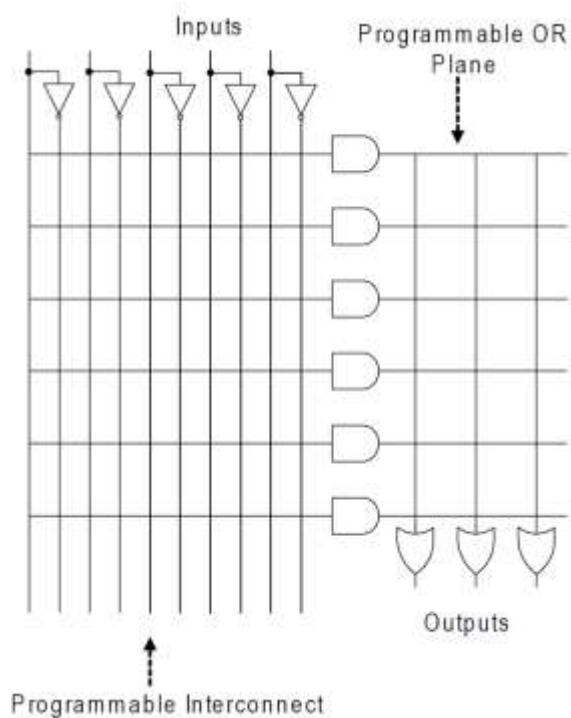

PLA

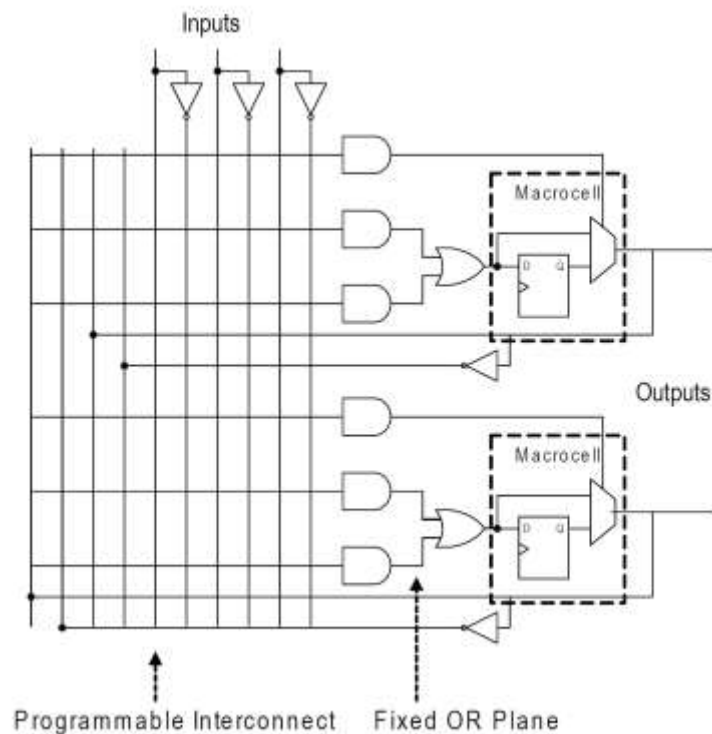

PAL

MacroCell

- 包含DFF，作为状态保持单元
- 包含选择器和三态门，可以作为一般/三态输出
- 包含回馈逻辑，返回状态给PLA的组合逻辑阵列

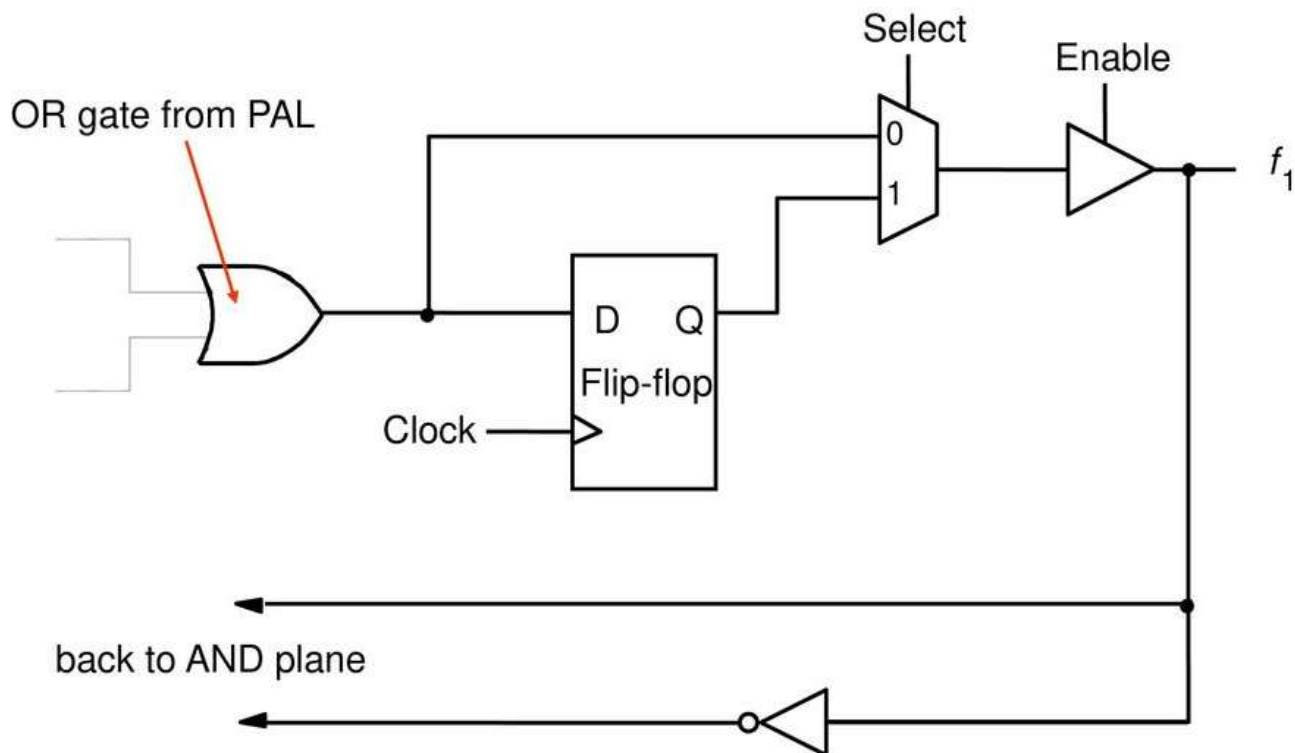

- 包含多个PAL模块的可编程逻辑器件
- PAL模块间用片上互连网络连接

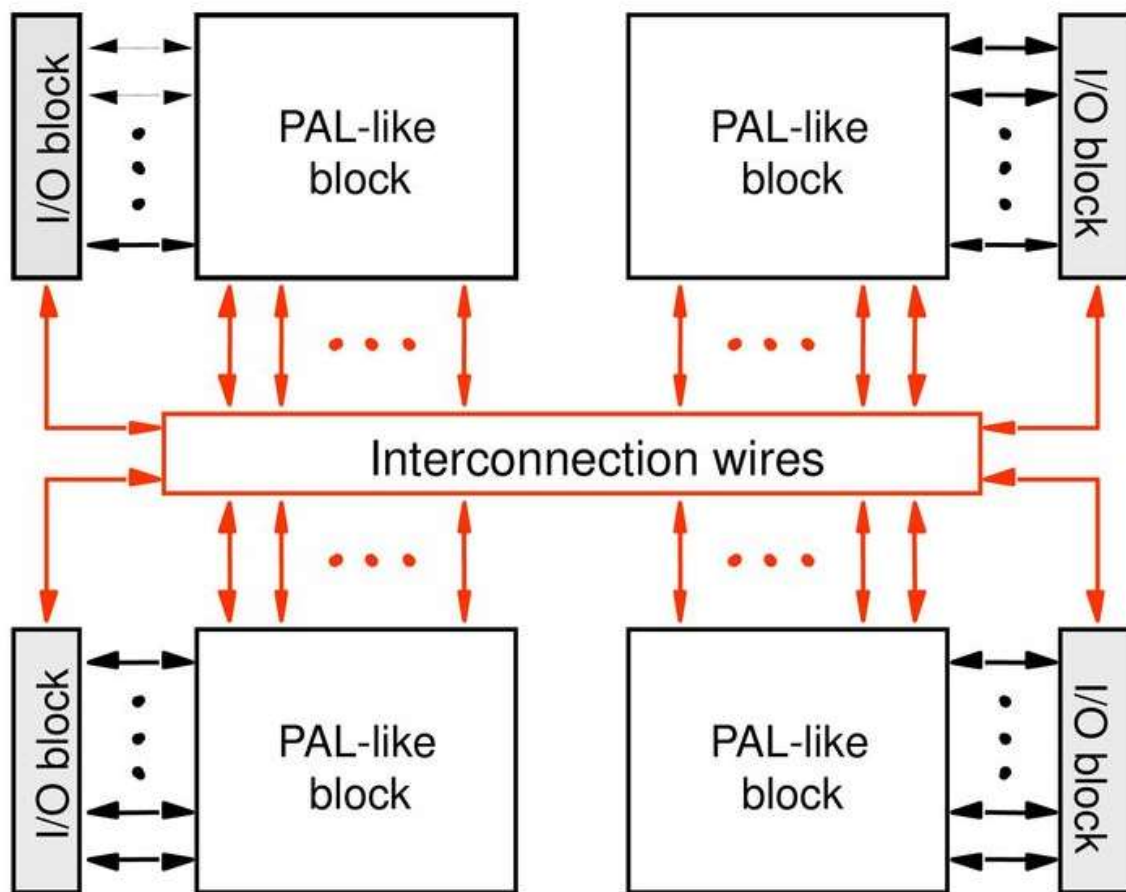

CPLD

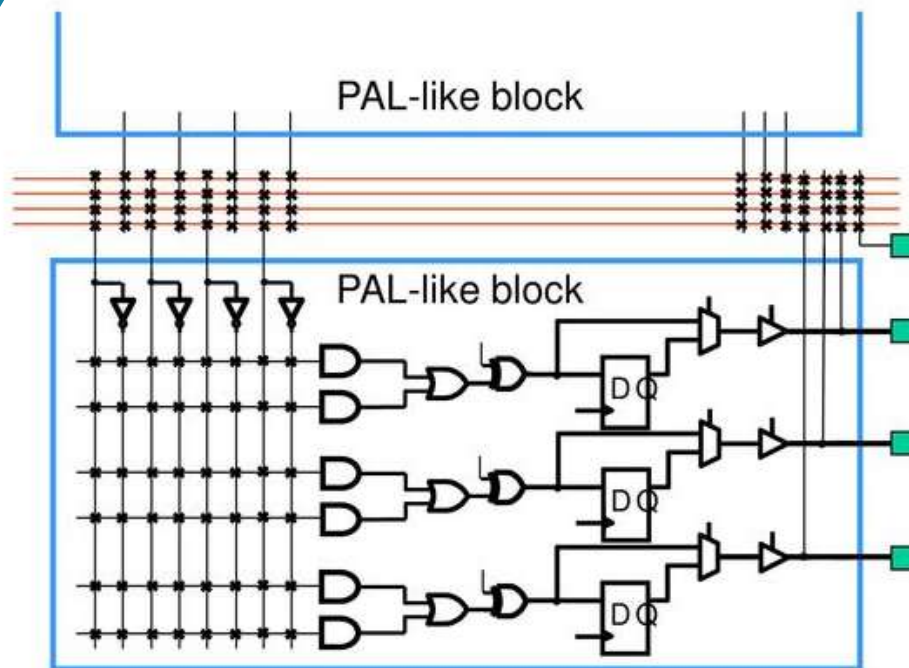
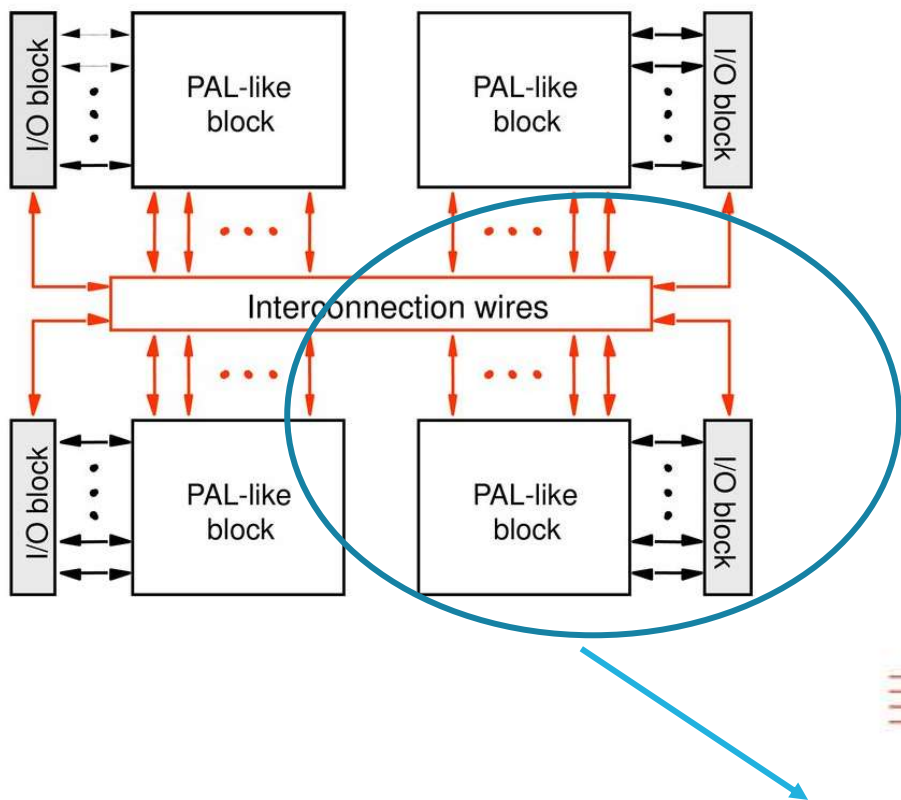

- FPGA由众多可编程逻辑块（CLB）构成
- CLB之间通过可编程的连接网络连接
- 与CPLD不同的是，FPGA的可编程开关由SRAM驱动
 - 上电需要配置，掉电丢失，但是面积代价小

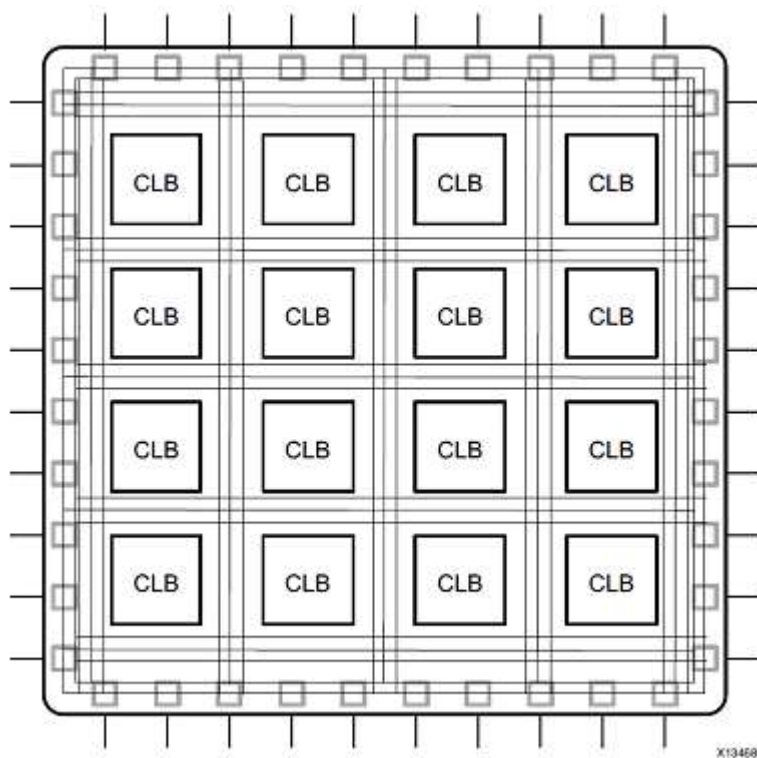

FPGA的连接网络

- CB: connection block, 固定连接
- SB: switching block, 可配置连接

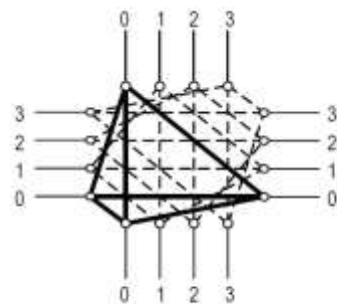

(a) Disjoint

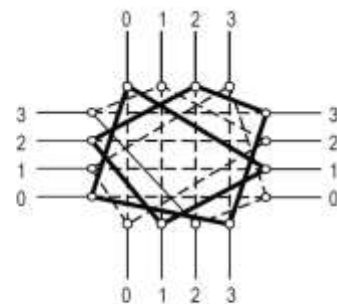

(b) Wilton

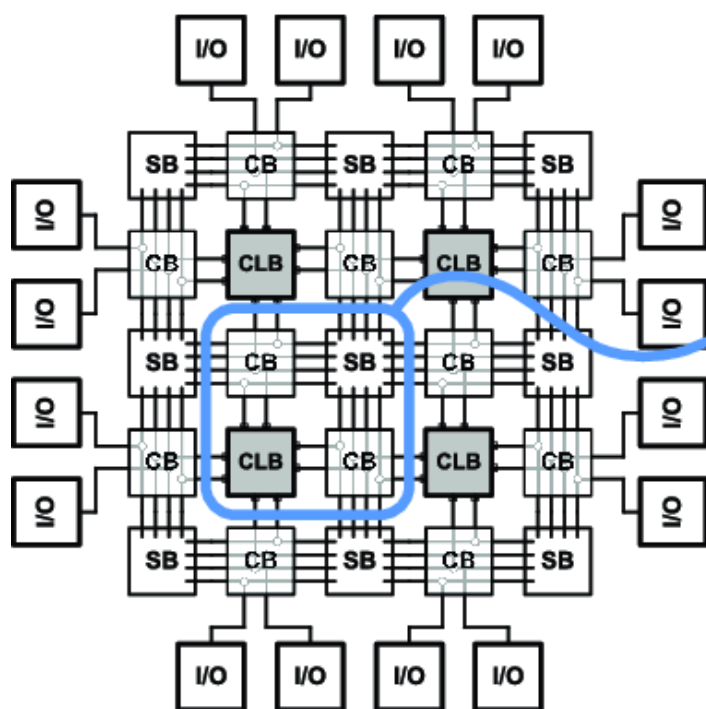

Routing channel (W tracks)

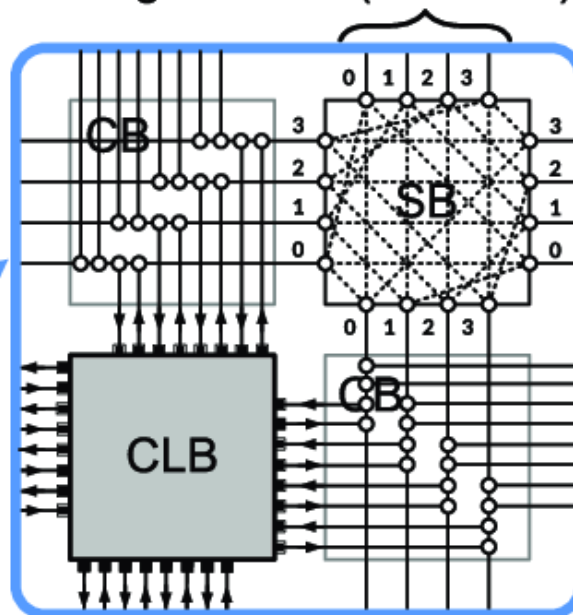

FPGA的CLB

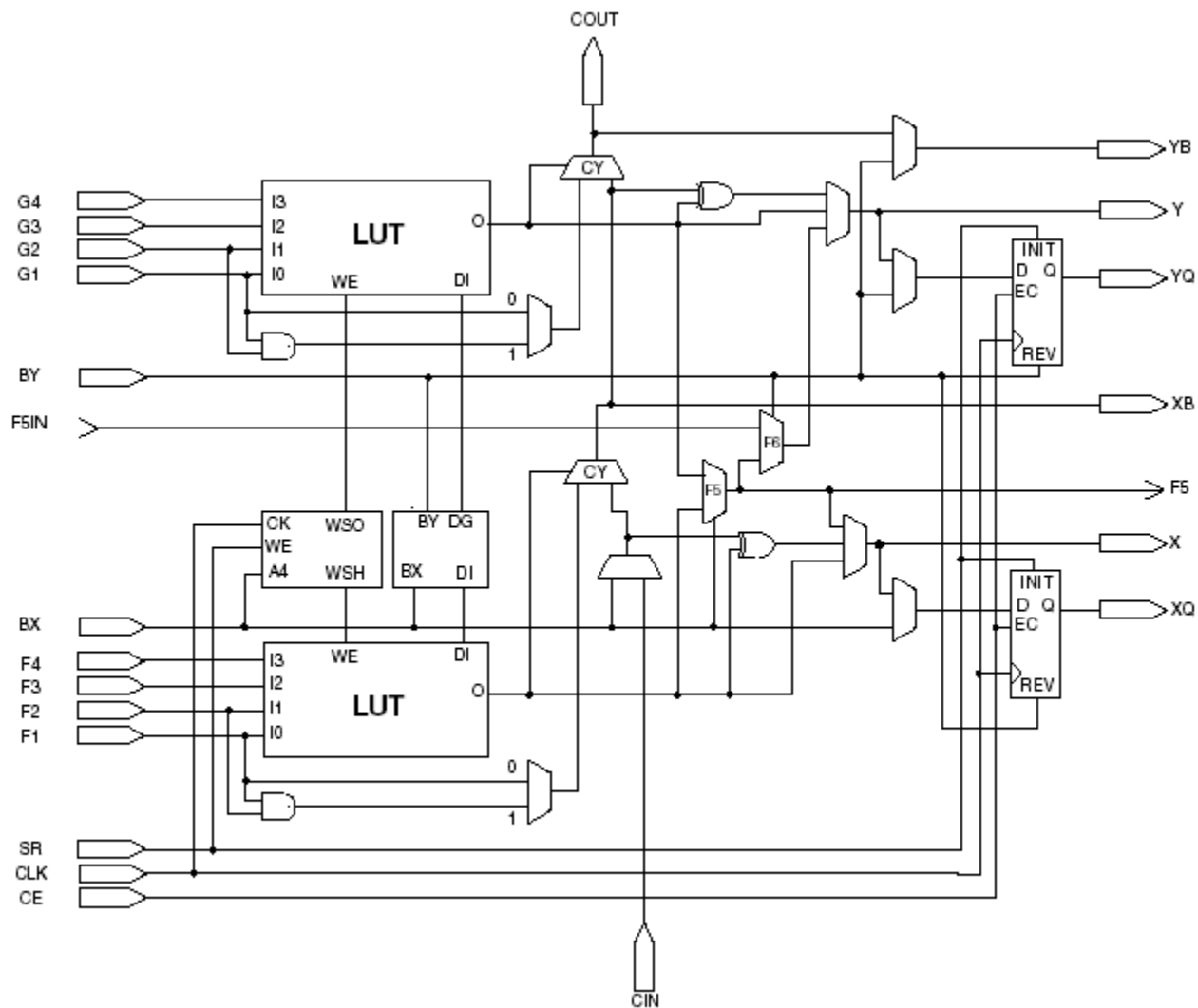

○更大的FPGA需要用Hierarchical的结构连接

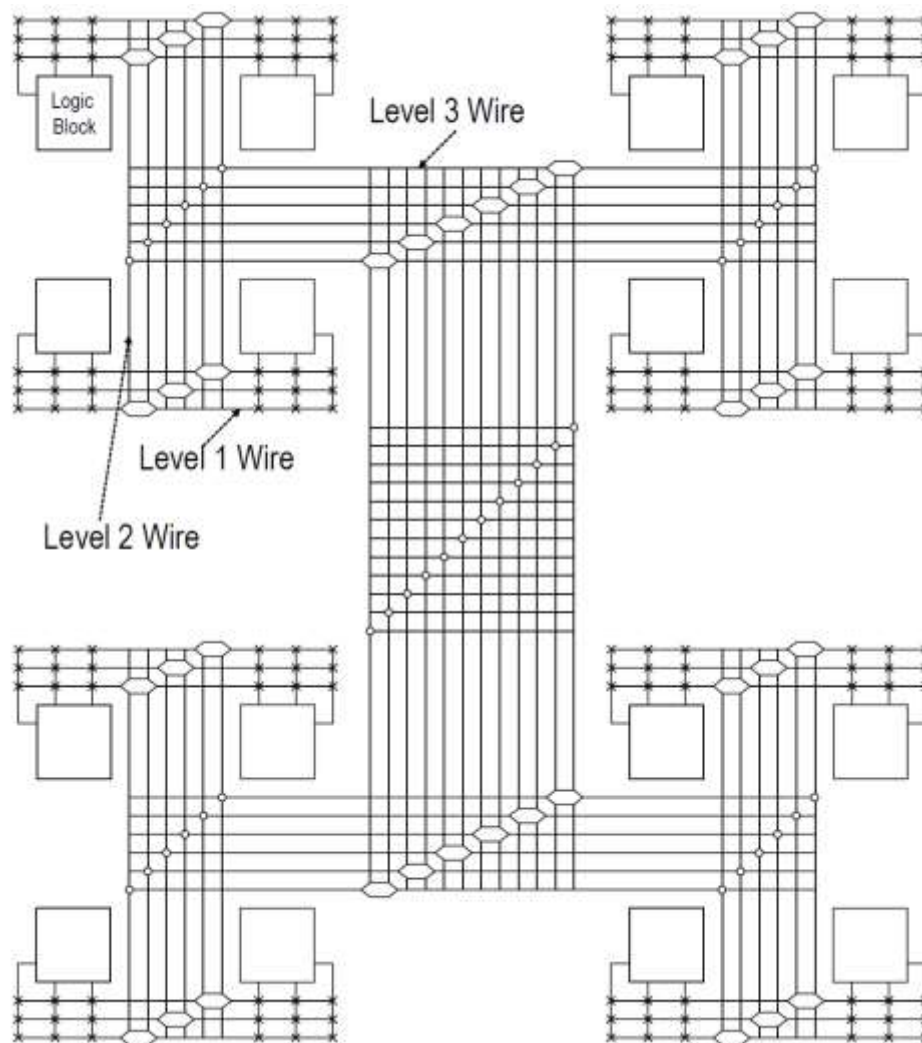

FPGA的内部资源

更复杂的FPGA包含多种异质IP

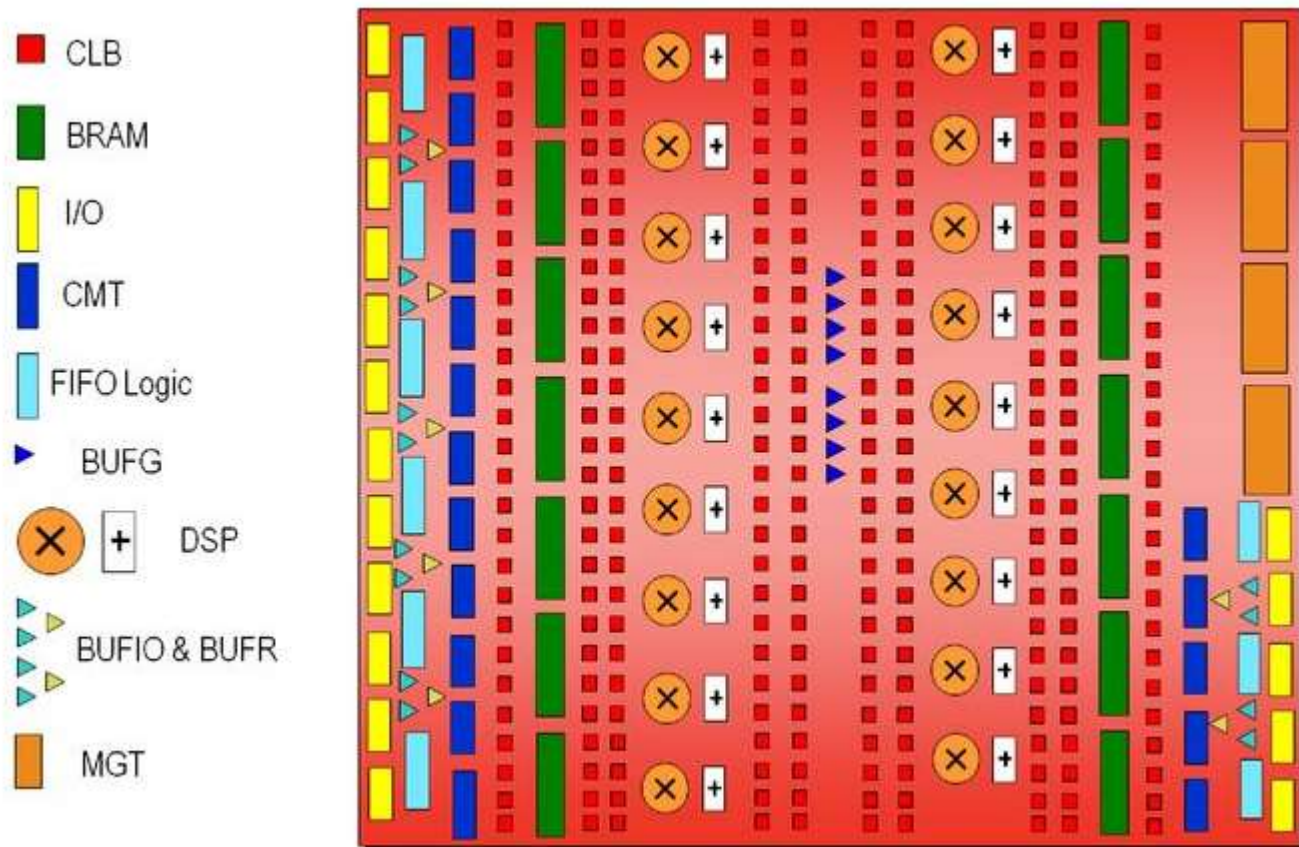

FPGA的配置

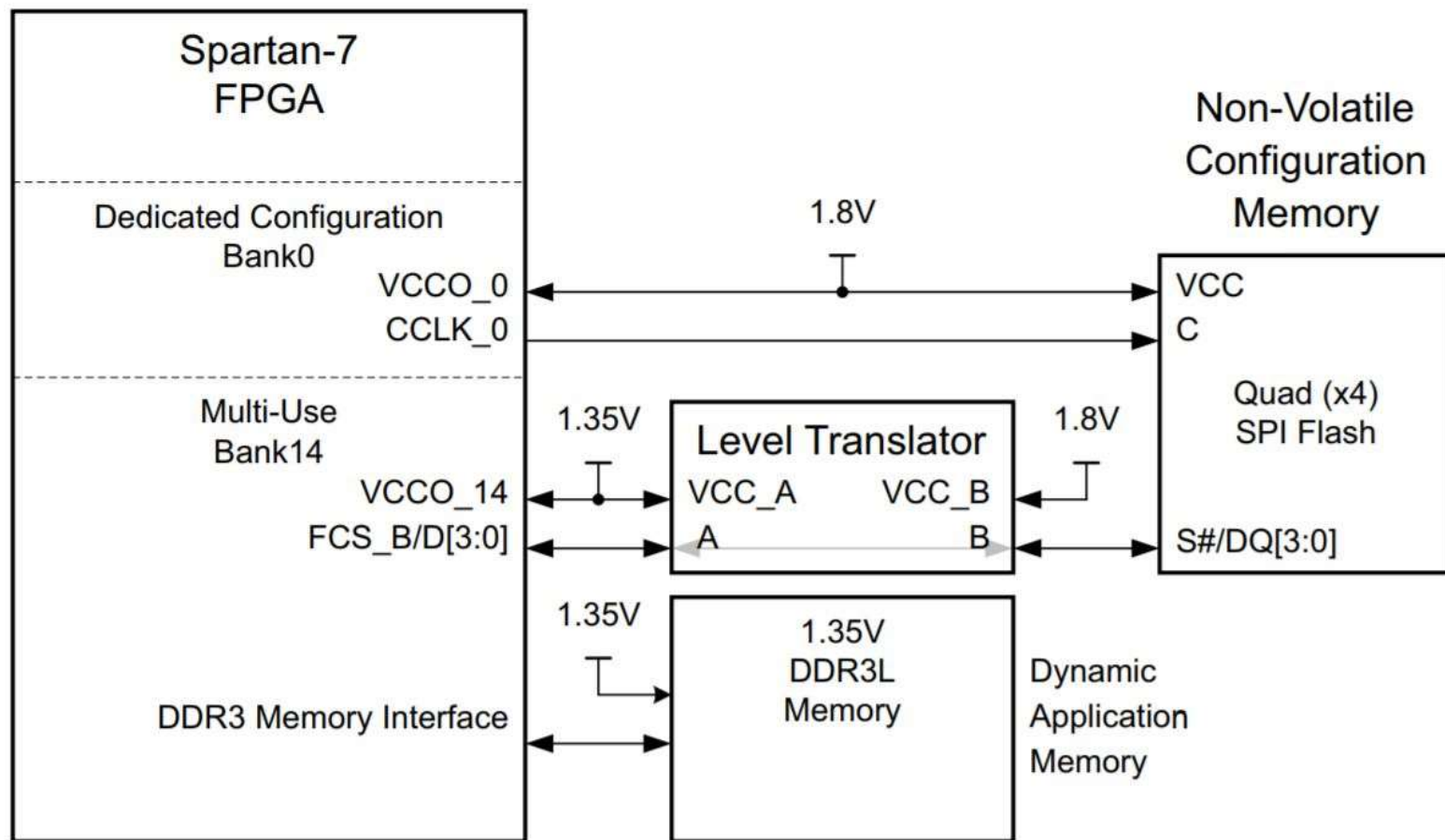

X18958-032417

Figure 1: Spartan-7 FPGA with 1.8V SPI Configuration Flash and 1.35V DDR3L

FPGA开发板 (Xilinx KC705)

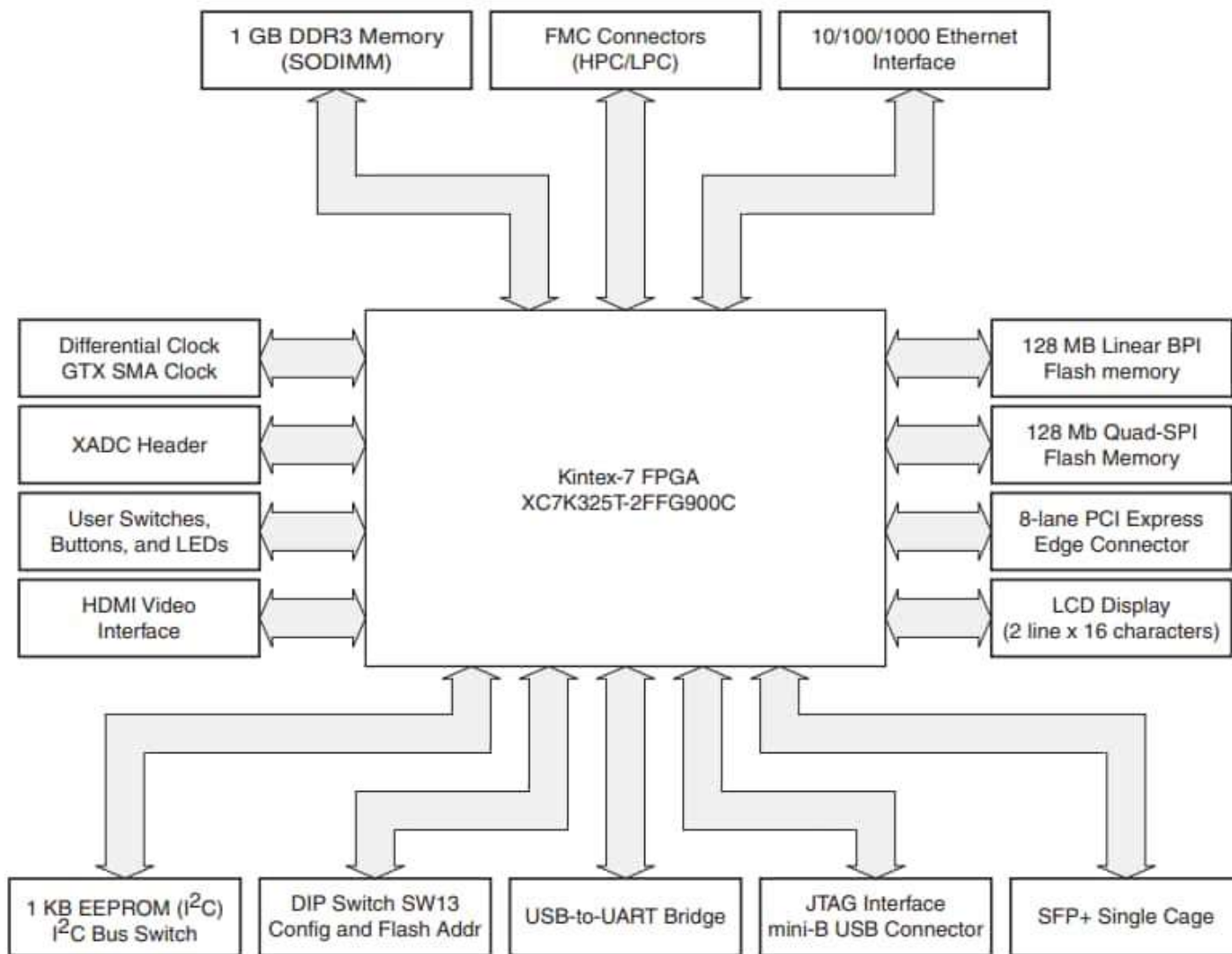

FPGA开发板 (Xilinx KC705)

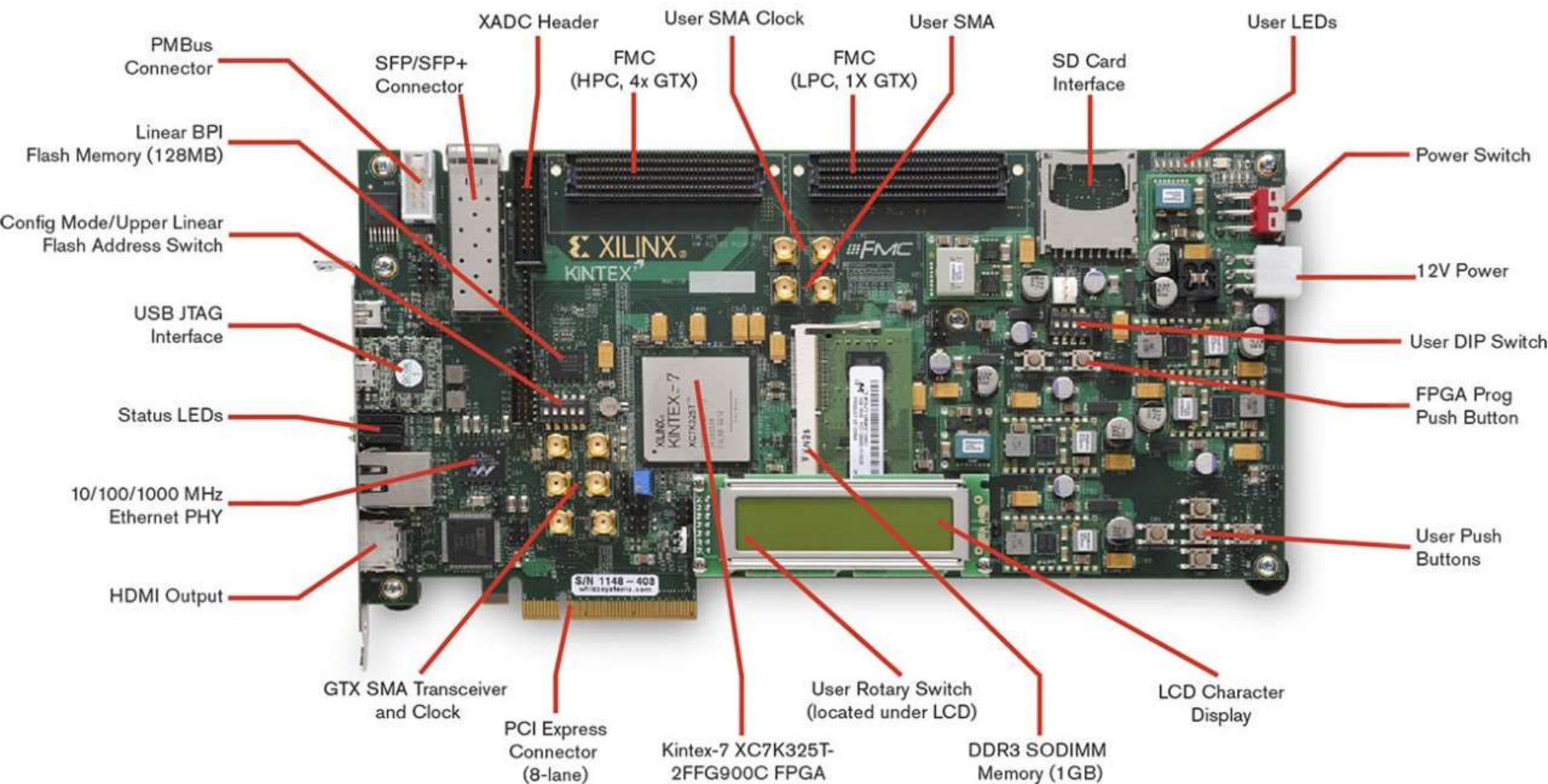

FPGA demo (Nexys4-DDR)

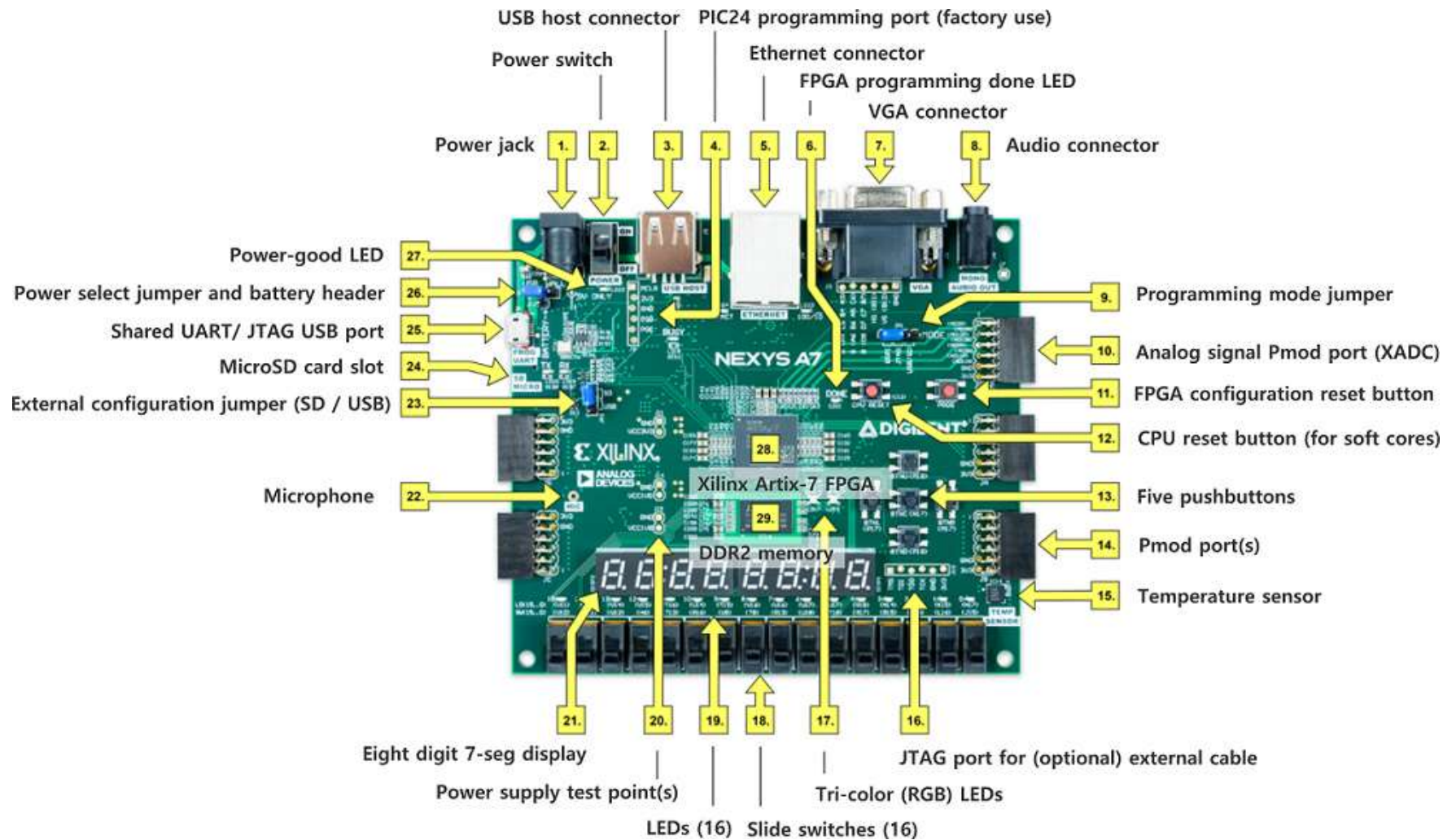

总结：考试范围（概念）

- 可编程逻辑电路
 - 半定制，可编程
 - CPLD和FPGA的区别
 - FPGA的配置

任何问题?

- FPGA和ASIC相比的优缺点比较。